



Meka Solar Nordic PV System Specification and Installation Instructions

Revision history

Revision	Date	Change	Author
0.1	02.01.2023	First draft	AkiL
0.2	01.08.2023	Second draft	VV
0.3	02.08.2023	Third draft	VV/MV
0.4	21.12.2023	Fourth draft	VV
1	17.04.2024	Different screws and updated pictures.	VV

CONTENT

1	Introduction.....	4
1.1	General Safety	4
2	Part list.....	5
3	Maximum allowed Snow and wind loads.....	7
3.1	Solar stand’s snow and wind loads.....	8
3.1.1	Snow loads.....	8
3.1.2	Wind loads.....	8
4	Electrical conductivity	8
5	Installation instructions.....	8
5.1	General instructions	10
5.2	Screw torques.	10
5.3	Stand dimensions.	10
5.4	Stand’s legs.....	12
5.5	C-Profile BS (Back Support).	14
5.6	C-Profilin extension.....	16
5.7	EC and MC clamps.	19
6	Maintenance and care.....	22
7	Disclaimer and Limitations:	23

Meka Pro Solar Panel Stand System

1 INTRODUCTION

This document gives basic information for Meka Solar Nordic PV System stand systems. It includes part list and installation instructions for Solar panel stand system together with acceptable snow and wind loads.

1.1 General Safety

Installing solar panel system requires special skill and knowledge determined in regulations applicable in a given country.

Only authorized and trained professional can install solar panel system. Installers are required to be aware of and acknowledge all potential risks of injury that could arise during the installation process, including risk of electric shock and other risks.

Solar panel system can be either ground-mounted or mounted on a foundation at ground level. The responsibility for designing appropriate support structures rests with the system installers.

During the installation of the system, it is essential to adhere to all applicable local, regional, and national regulations. If required, ensure to obtain a building permit before proceeding.

Ensure that all equipment used is specifically designed and appropriate for solar electric systems.

Avoid sitting, standing, stepping, or walking on modules, including their frames. Do not immerse any part of the module in water unless it's natural rainfall or regular cleaning. Continuous impact with water should also be avoided.

Avoid installing or operating modules in areas characterized by excessive salt, dust, hail, snow, sand, air pollution, chemical activity, acid rain, soot, etc. Solar panel stand system should be positioned in areas where the prevalence of aggressive substances such as salt, salt-water, or other corrosive agents will not compromise the safety and operational effectiveness of the modules.

Solar panel stand system must not be installed in areas where the generation or concentration of flammable gases is prevalent.

Verify that the module installation method and bracket system possess sufficient strength to withstand the designated load conditions. It is imperative to consistently adhere to the safety instructions and precautions provided with the module support frames.

During the installation make sure that the solar panel stand system can effectively endure the anticipated local wind and snow loads.

2 PART LIST

Part list for solar panel stands is shown below.

NOTE: Ground foundation and its fixing bolts are not included.



C-Profile 48x98 L=XXXX XPG



AS L=XXXX HDG



J-Extension XPG



RTF-S-10 XPG



SOLAR FOOT 48x98 XPG



C-Profile BS



SOLAR EC30/35/40



SOLAR MC30/35/40



C-Profile SC

RS8 HOGs and washers
RS SOLAR AS

3 MAXIMUM ALLOWED SNOW AND WIND LOADS

MEKA® solar panel stand can bear following loads. Maximum loads are defined for by simulations. Maximum loads are not allowed to exceed and are only valid if solar panel stand is assembled according to instructions by qualified person.

3.1 Solar stand's snow and wind loads

3.1.1 Snow loads

Up to 3 kN/m², depending on stand type and panel size.

3.1.2 Wind loads

Up to 25 m/s, depending on stand type and panel size.

4 ELECTRICAL CONDUCTIVITY

Panel system electrical conductivity needs to be measured according to local standards and requirements given by local authorities.

Solar panel ground system can be grounded using accessories from a different manufacturer, as long as those accessories are certified for grounding modules and are installed in strict accordance with the manufacturer's provided instructions.

5 INSTALLATION INSTRUCTIONS

Installation instructions for MEKA® solar panel stand systems are described in this paragraph.

NOTE:

This content is intended to present and illustrate generally acceptable installation methods for MEKA® solar panel stand systems. Contractor or installer must verify needed snow and wind load requirements of each project and installation site.

These guidelines and information do not intend to cover all details or variations in each system nor provide for every possible installation contingency. This content does neither intend to replace the responsibility of the contractor and installer to acquire knowledge of and apply the valid laws, rules, regulations, and standards on related to solar system installations in each individual project and site. The installation method shall always be finally approved by the construction site supervisor and relevant authorities.

To prevent galvanic corrosion, ensure that all utilized components are compatible with the stand system material. It's important to note that damages resulting from galvanic corrosion are not covered under the warranty.

Using stand systems with varying configurations (such as grounding and wiring) in a single system is not advisable.

Arrange or secure excessive cables appropriately, such as by affixing them to the mounting structure using non-metallic cable ties or other suitable fasteners.

When employing systems from various manufacturers on the Mekas solar panel stand system, ensure their compatibility, and diligently adhere to their individual instructions and guidelines.

5.1 General instructions

- Mounting angle is 30° or 40° (GS3)
- Maximum distance between legs is 2,8 m
- Maximum c-profile overshoot 0,5 m, where solar panels are attached to.
- Maximum length of Solar ground stand 40m.
- Washers must be used in all joints. In some specific joints, DIN 9021 type washer are required to meet specified snow and wind loads in this cases washer must put in both sides of the screw.

5.2 Screw torques.

Screw torques for each screw or bolt type is shown table below.

In general, torque values are specified for 4.6 grade bolts if not otherwise stated.

NOTE: Each solar foot must be fixed to foundation structure with at least four grade bolts, always make sure that installation is suitable for foundation and its structure supports stands weight + possible wind and snow loads.

Table 1. Screw joint torque values

Part	Bolt type	Torque
MEKA RS KSF	M10x30	22 Nm
MEKA Solar EC	M8+sliding nut	13 Nm
MEKA Solar MC	M8+sliding nut	13 Nm

5.3 Stand dimensions.

Stand dimensions are shown below.

NOTE: Dimensions H1 and H2 are only showing height above ground level or foundation structure

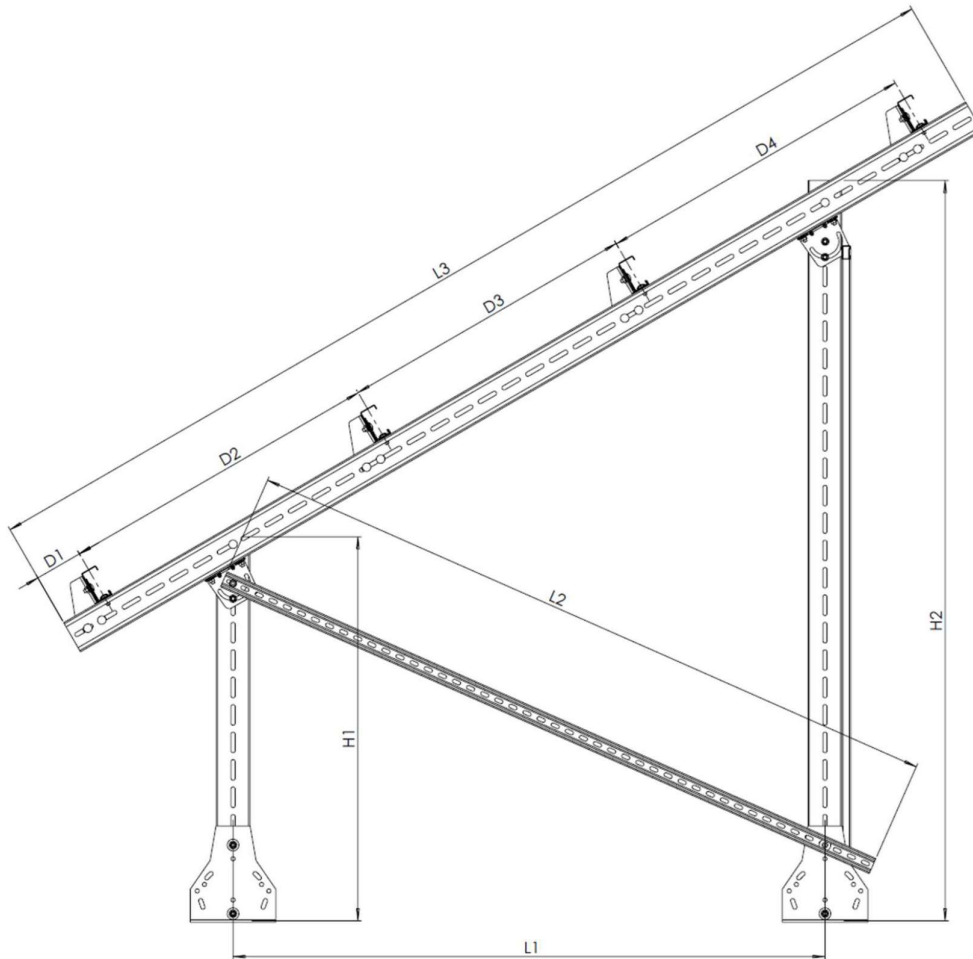

Figure 1. Stand dimensions.

Dimension	L1	L2	L3	H1	H2	D1	D2	D3	D4	Kulma
GS3 Small stand panel, size max. 1800x1200 (mm)	1728	2070	3040	1120	2160	140	940	880	940	30°
GL3 big stand, panel size over 1800x1xxx (mm)	2500	2790	3840	1200	2640	190	1160	1244	1160	30°

Dimension	L1	L2	L3	H1	H2	D1	D2	D3	D4	Kulma
GS3 Small stand panel, size max. 1800x1200 (mm)	1523	2070	3040	1280	2560	138	1102	560	1102	40°

Table 1. Stands dimensions.

5.4 Stand's legs.

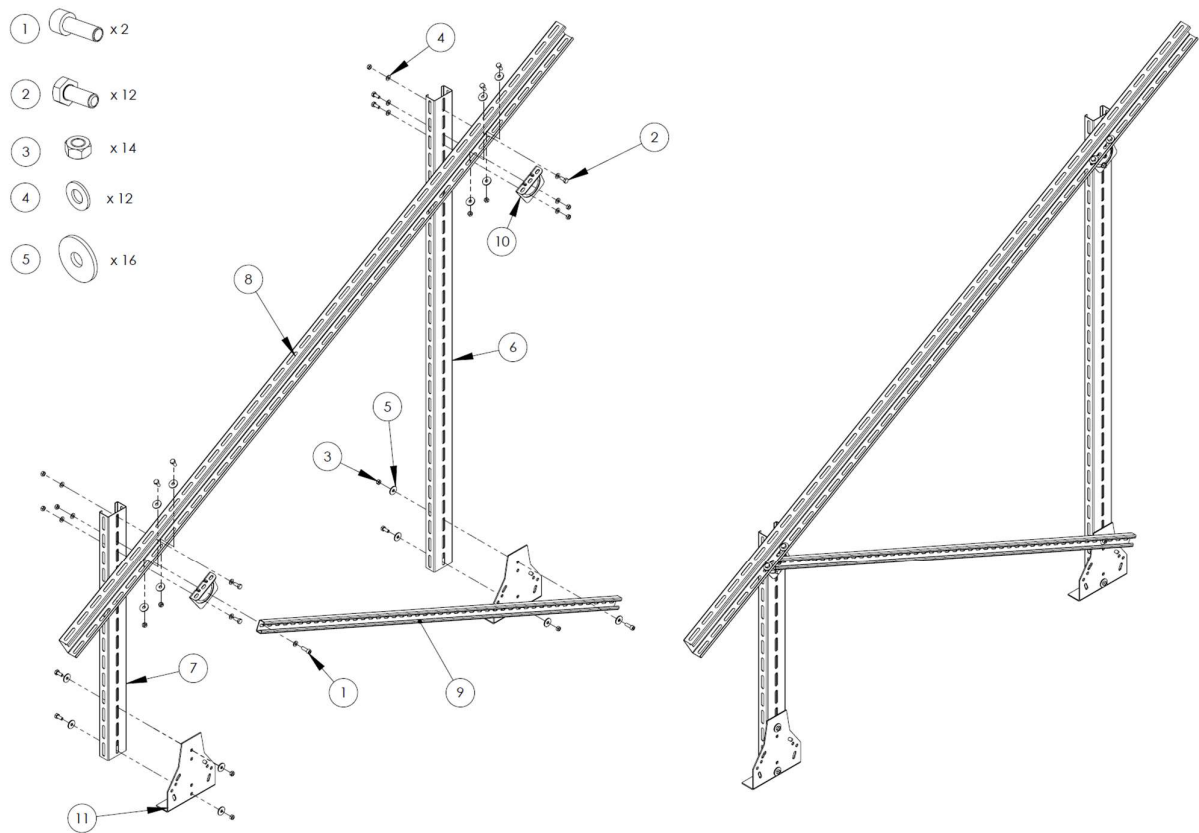

Figure 2. Stand legs' exploded-view and normal view.

MEKA® solar panel stand legs are installed as shown in Figure 2 above. There are four screws in each RTF-S-10 and one screw for each C-Profile crossing point.

Note! Ensure that the foot is positioned the same way as shown in the above image. When viewed from the front, the upright C-profiles should open to the left.

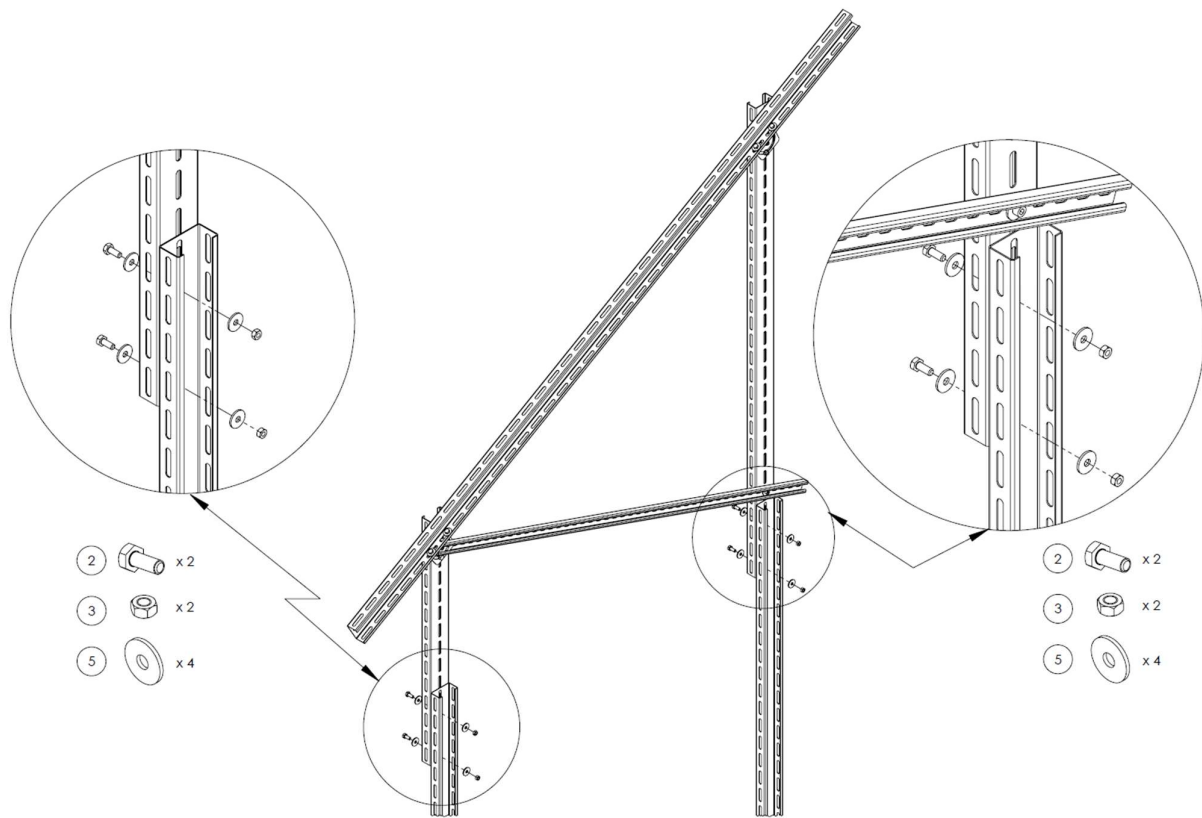

Figure 3. Pile-Mounted leg.

If the scaffold has separate pile-mounted legs, they are fastened with two screws so that the legs are back to back at a distance of at least 335 mm, and the screws are attached with one as high as possible and the other as low as possible. If separate pile-mounted legs are not used and the legs are a continuous C-profile, they are first piled into the ground, and then the assembly of the legs is continued according to the instructions."

Note! Ensure that the foot is positioned the same way as shown in the above image. When viewed from the front, the upright C-profiles should open to the left.

Pos	Name
1	C-Profile (see length in table above)
2	C-Profile (see length in table above)
3	C-Profile (see length in table above)
4	AS HDG (see length in table above)
5	RTF-S-10
6	Washer Din 9021
7	R8 HOG
8	Solar Foot

Table 3. Parts of the system.

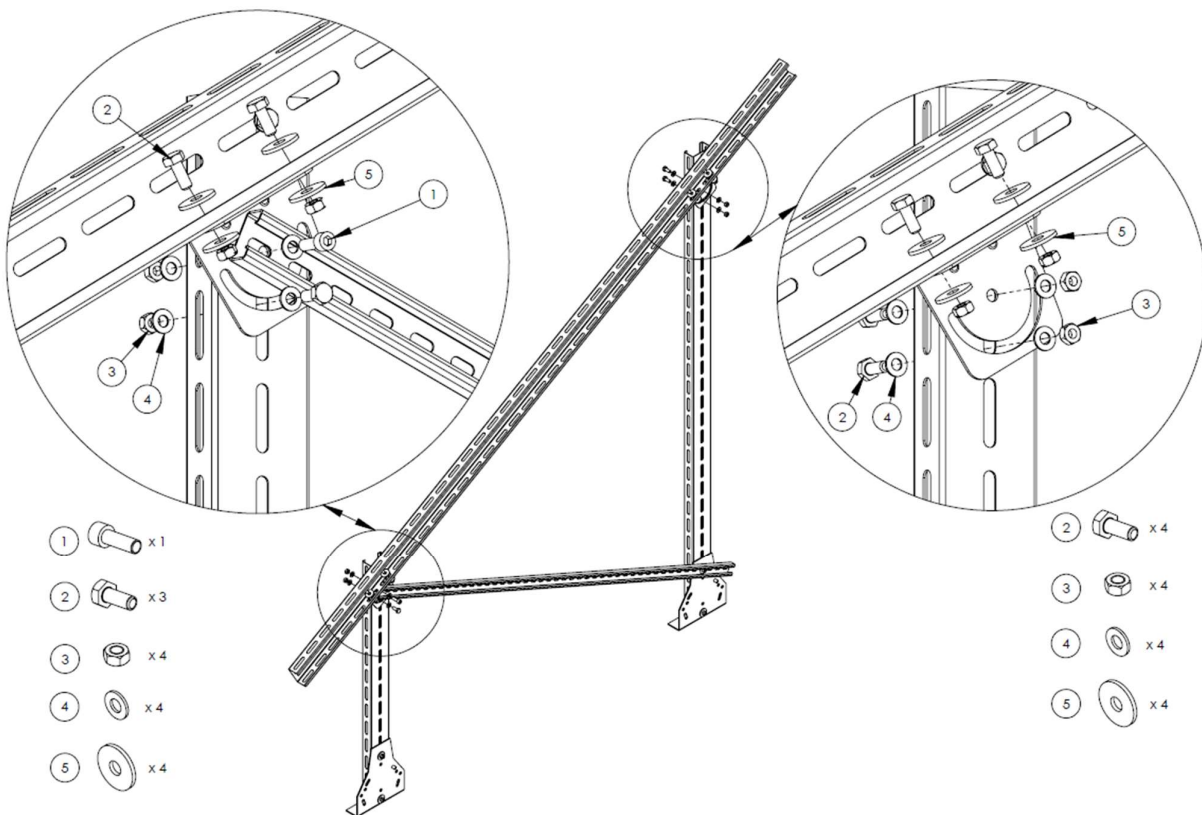

Figure 4. RTF-S-10 installation as shown in picture.

5.5 C-Profile BS (Back Support).

For each horizontal C-profile, install one C-Profile BS with three screws in the location of the foot, following the arrangement shown in Figure 5.

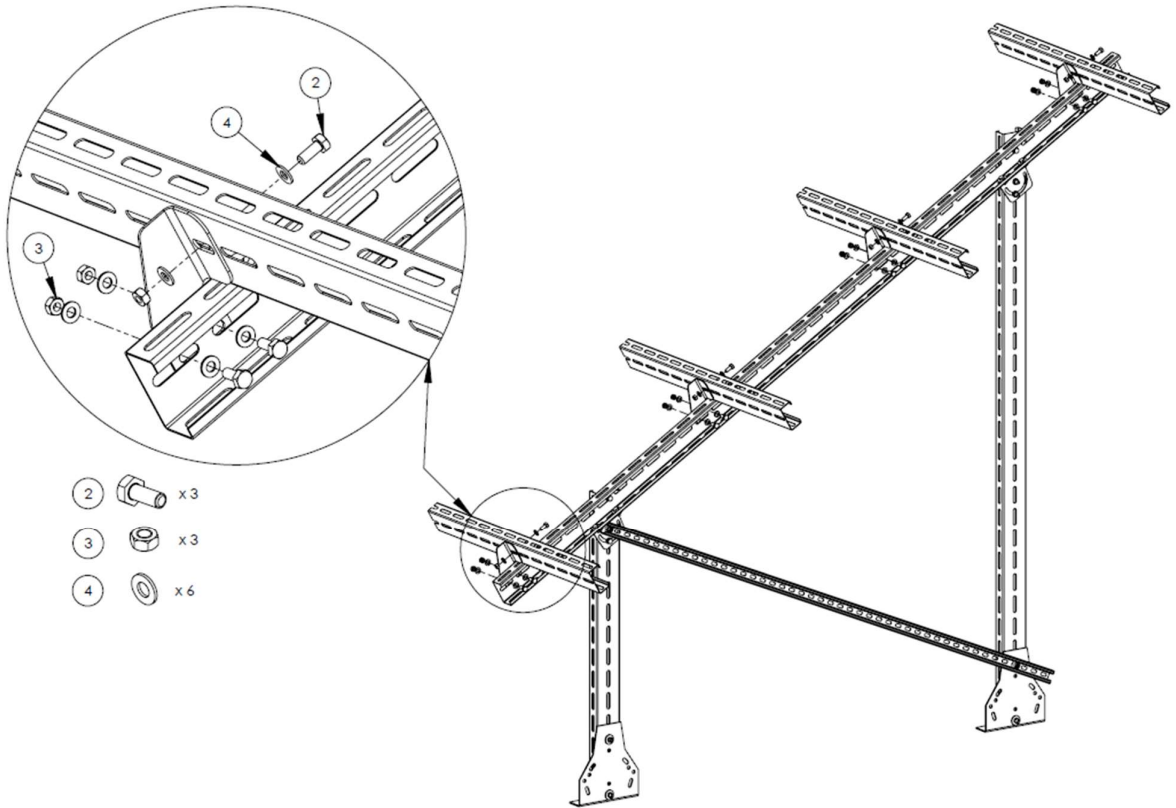

Figure 5. C-Profile BS installation.

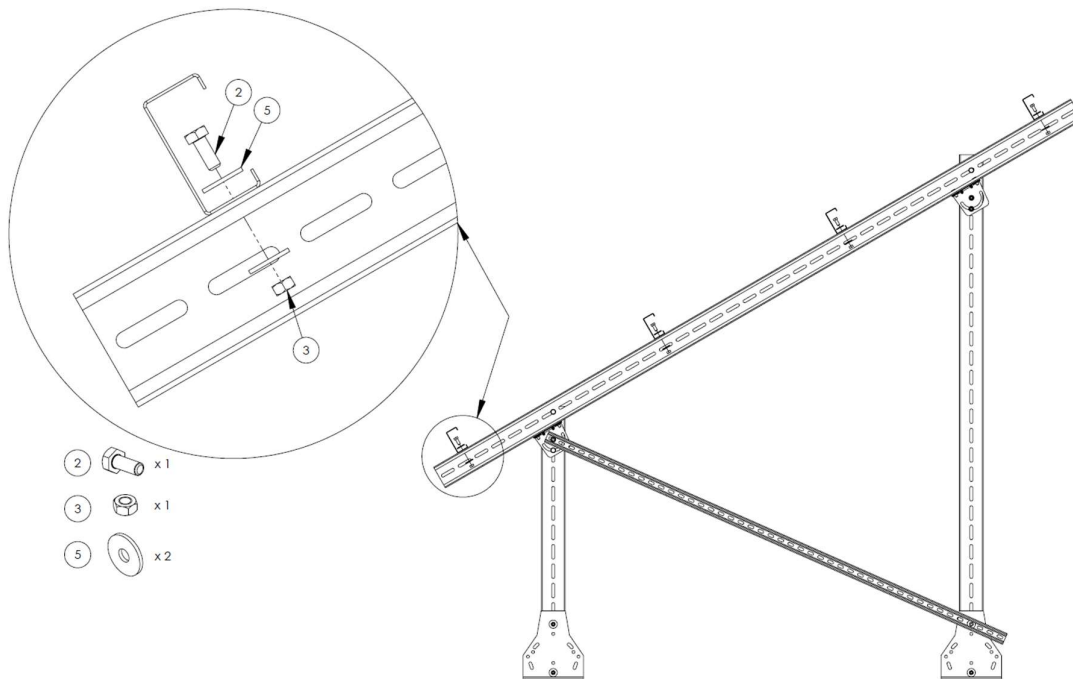

Figure 6. Attachment of Horizontal C-Profiles.

5.6 C-Profilin extension.

C-Profile extension is made with C-Profile J extension. It will be installed with eight R8 Screws sets for each extension, like in figure 7.

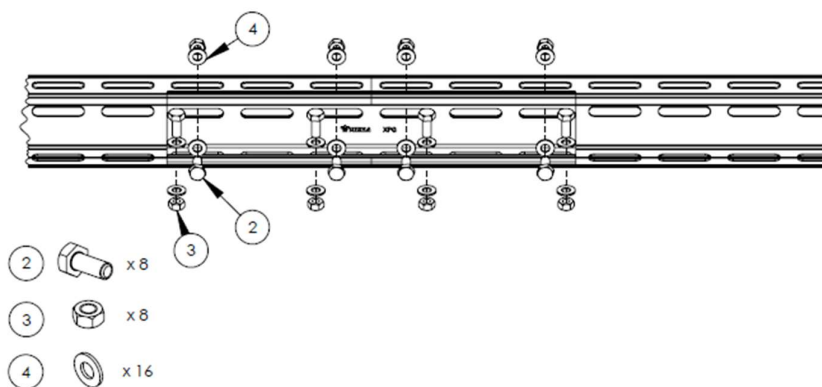

Figure 7. C-profile J extension.

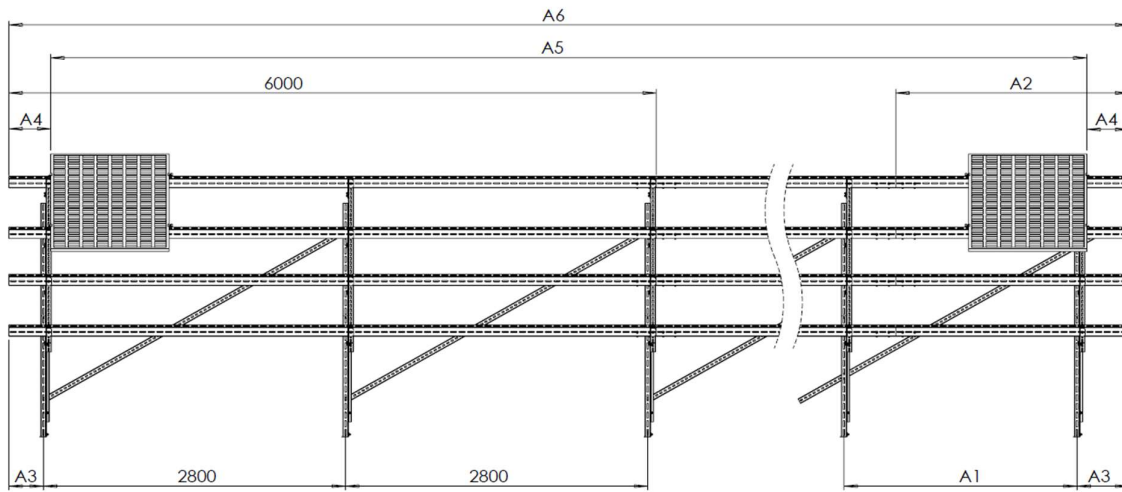

Figure 8. Illustration of the scaffold with diagonal slats.

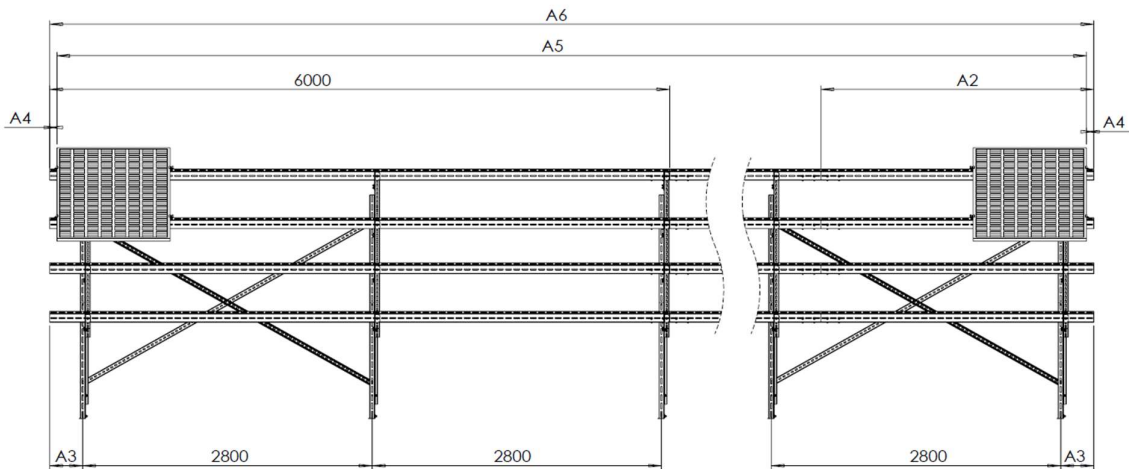

Figure 9. Illustration of the scaffold with X-slats.

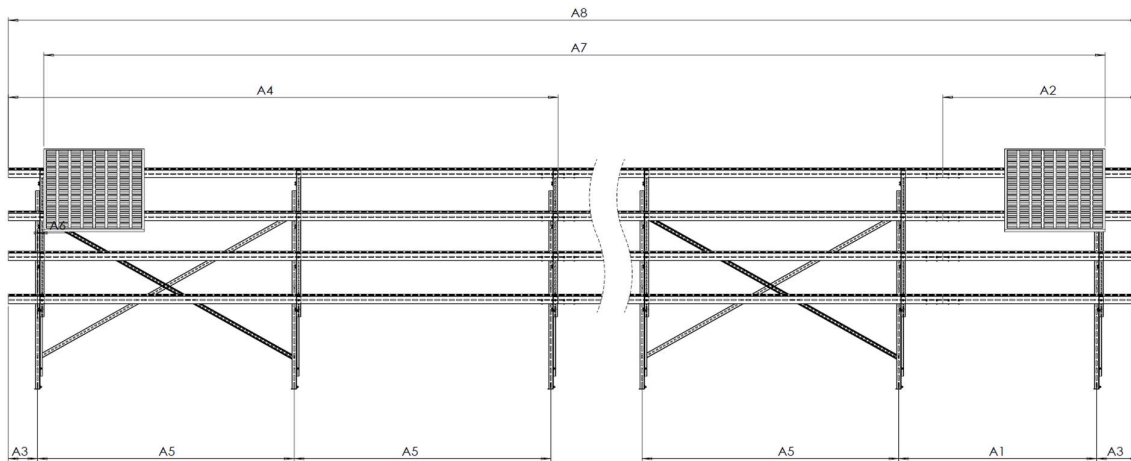

Figure 10. Illustration of the scaffold with X-slats when the last leg span is shorter.

On the backside of the scaffold, AS L=xxx HDG rails are installed diagonally to support the structure. The number of rails depends on the ordered scaffold. Each AS rail is attached with two RS SOLAR AS screws and washers.

The ready-made packages include the following quantities and are installed as depicted in Figure 8, with diagonal placement:

8004270 Nordic PV System GS3 2x6: Three AS L=3015 HDG

8004271 Nordic PV System GS3 2x6: Three AS L=3015 HDG

8004272 Nordic PV System GS3 2x12: Five AS L=3240 HDG

8004274 Nordic PV System GS3 2x12: Five AS L=3240 HDG

If the site has a project-specific scaffold, refer to the offer to determine whether the installation follows Figure 8, 9, or 10

5.7 EC and MC clamps.

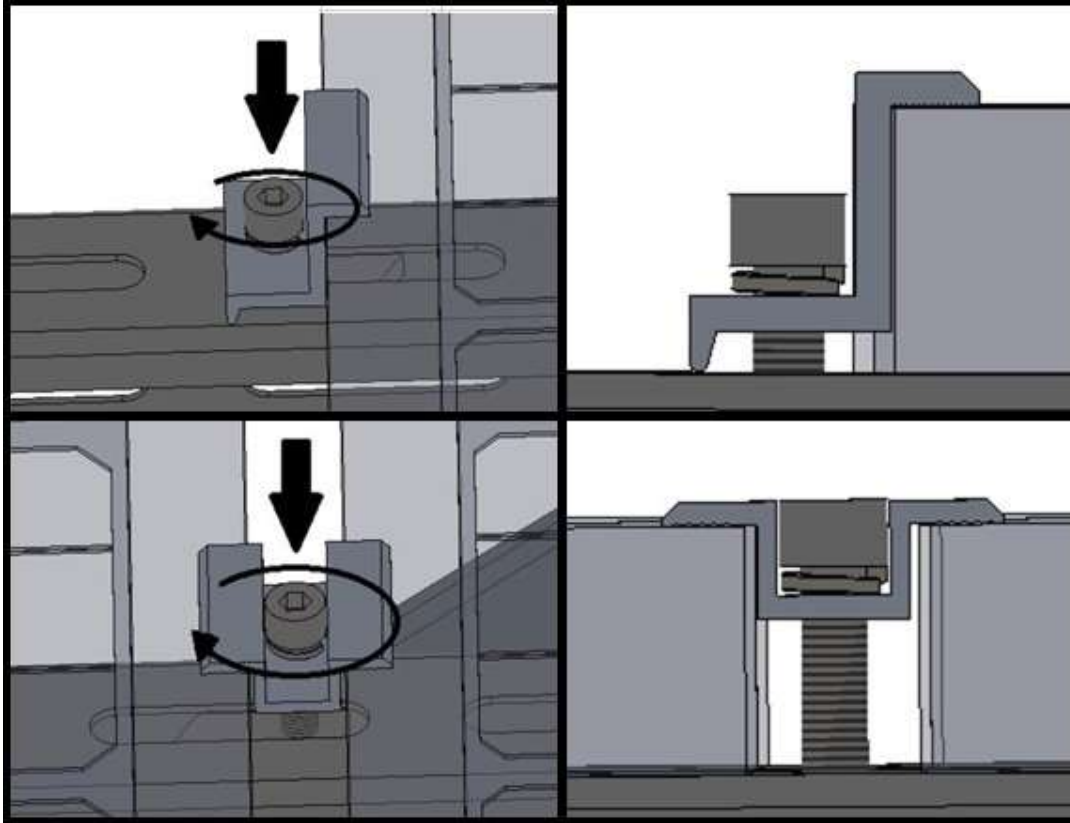

Figure 11. EC and MC clamps.

If you are using the C-Profile SC bracket, proceed to section 5.8. The panels are attached to the scaffold using MC and EC brackets. The brackets are installed through the C-profile and secured by turning the screw clockwise.

Make sure that this is in-line with installing guide of the panel that is used, and that installation will carry the defined snow and wind loads.

5.8 C-Profile SC.

Attachment with C-Profile SC, assemble EC/MC with C-Profile SC as depicted in Figure 9. Attach this to the edge of C-Profile as shown in Figures 8 and 9. Tightening can be done from below the panels.

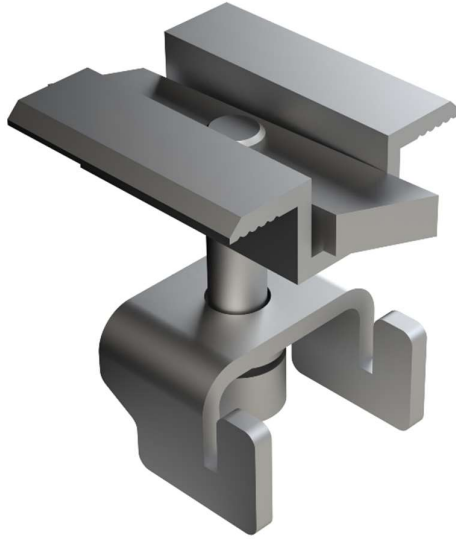

Figure 12. C-Profile SC & MC

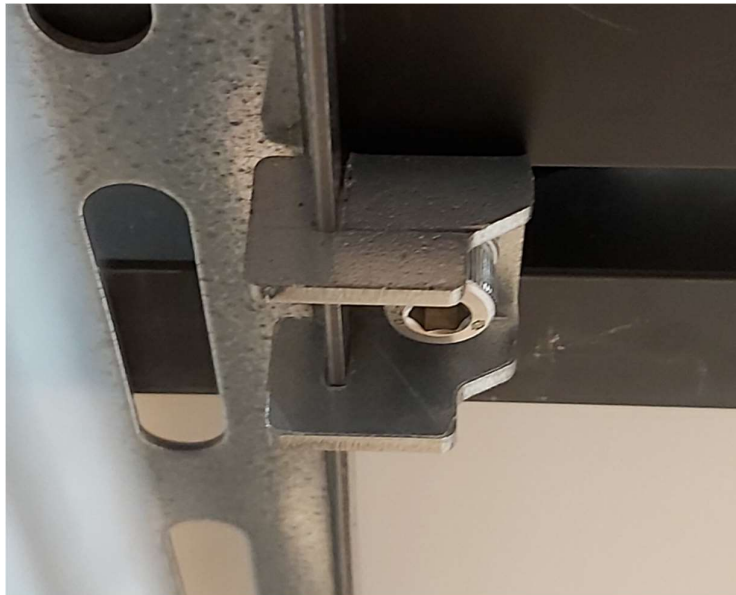

Figure 13. C-Profile SC attachment to c-profile and solar panel.

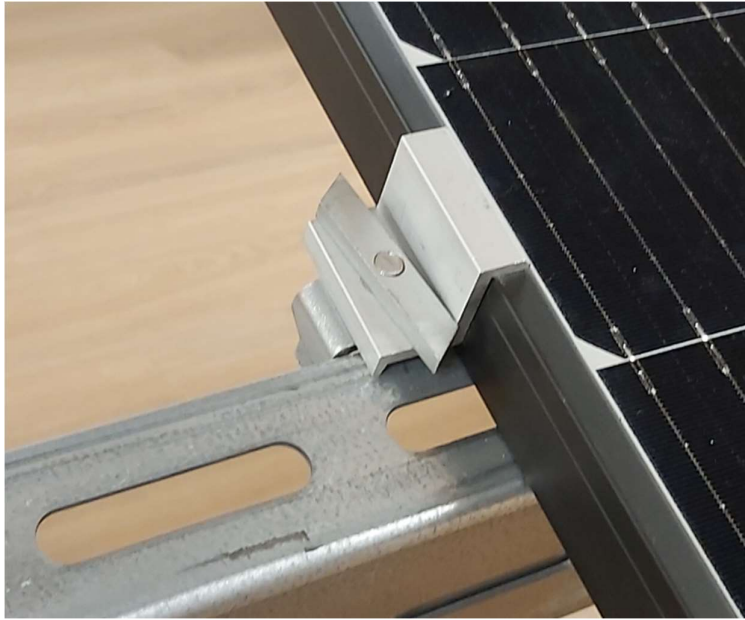

Figure 14. C-Profile SC attachment to C-Profile and solar panel.

6 MAINTENANCE AND CARE

Proper maintenance and care are crucial for ensuring the long-term performance and durability of your solar panel system. Follow these guidelines to keep your system in optimal condition:

1. **Regular Inspection:** Conduct routine visual inspections of your solar panels supporting structures. Look for any signs of damage, wear, or debris accumulation. Larger cuts and scratches must be covered with zinc spray or paste.
2. **Safety First:** When performing maintenance, prioritize safety. If work with electrical components, follow appropriate safety precautions or consider hiring a professional.
3. **Severe Weather:** After severe weather events like storms or heavy snowfall, check the stand system for damage. In snowy regions, gently remove snow accumulation to restore optimal performance.
4. **Professional Inspection:** Schedule a professional inspection annually or as recommended by the manufacturer. They can identify issues that might not be visible during routine checks.
5. **Manufacturer's Guidelines:** Always refer to the manufacturer's maintenance guidelines and recommendations specific to your solar panel ground system.
6. **Warranty:** Understand your system's warranty and any maintenance requirements outlined within it. Some warranties may require regular maintenance to remain valid.

By following these maintenance and care practices, you can help ensure the efficient operation and longevity of your solar panel system.

7 DISCLAIMER AND LIMITATIONS:

The following statements outline the manufacturer's disclaimers and limitations regarding the use, installation, operation, and maintenance of the solar panel stand system:

1. **Limited Control and Liability:** The stand system manufacturer holds no responsibility and explicitly disclaims liability for any losses, damages, or costs arising from the use, installation, operation, or maintenance of the PV (photovoltage) product, as these factors are beyond the manufacturer's control.
2. **Third-Party Rights:** The module manufacturer does not assume responsibility for any potential patent infringements or violations of third-party rights resulting from the use of the PV product. The use of the product does not grant any implied or explicit license under any patent or patent rights.
3. **Information and Warranty:** While the information provided in these instructions is based on the module manufacturer's knowledge and experience. It is not considered as a warranty, expressed or implied. This includes product specifications, recommendations, and other details. The manufacturer reserves the right to modify the instructions, product specifications, or product data sheet without prior notice.

It is essential to thoroughly understand and consider these disclaimers and limitations when using, installing, operating, and maintaining the photovoltaic product.